

THE PHYSICS DEPARTMENT OF MCGILL UNIVERSITY:

A BRIEF HISTORY 1889-1939

Montague Cohen, Ph.D., FCCPM, F.Inst.P.

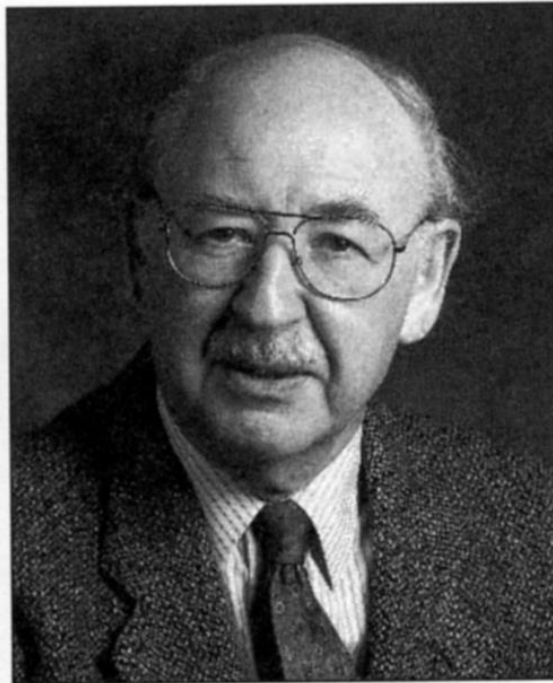

Professor Montague Cohen

Dr. Montague Cohen (1925-2002) was foremost a scientist, and he continued to work actively in his chosen field of radiology and medical physics until he died on January 28, 2002. Following a B.Sc. and Ph.D. at London University, Imperial College, he held positions in research physics and as a medical physicist of the London Hospital (1948-1961), the International Atomic Energy Agency (1961-1966), the London Hospital and London Medical College (1966-1975). In 1975, McGill managed to attract Monty to a professorship in the Departments of Radiation Oncology and Physics, and in 1979 he was appointed Director of the Medical Physics Unit. He held memberships in many professional societies in several countries, received various awards, including the prestigious Rontgen Prize of the British Institute of Radiology. He authored more than 100 papers, and several books and was frequently interviewed regarding radiation and radiation hazards - as a scientist he was devoted to increasing knowledge and understanding of science within the general population. For Monty the understanding of science was a joy, and he wished to share that joy with others. Monty was a devoted scholar on the subject of Ernest Rutherford and served as Curator of the Physics Department's Rutherford Museum from 1984 until his death. As its able Curator, he would give visitors fascinating talks about Rutherford. In 2001, the Department of Physics created the virtual Ernest Rutherford Museum site, where visitors can view digital facsimiles of the surviving Rutherford artifacts online (<https://www.physics.mcgill.ca/museum/>). In parallel to his activities as curator of the Rutherford Museum, he began to write a history of the McGill Physics Department that is the subject of the present publication.



1904-1905

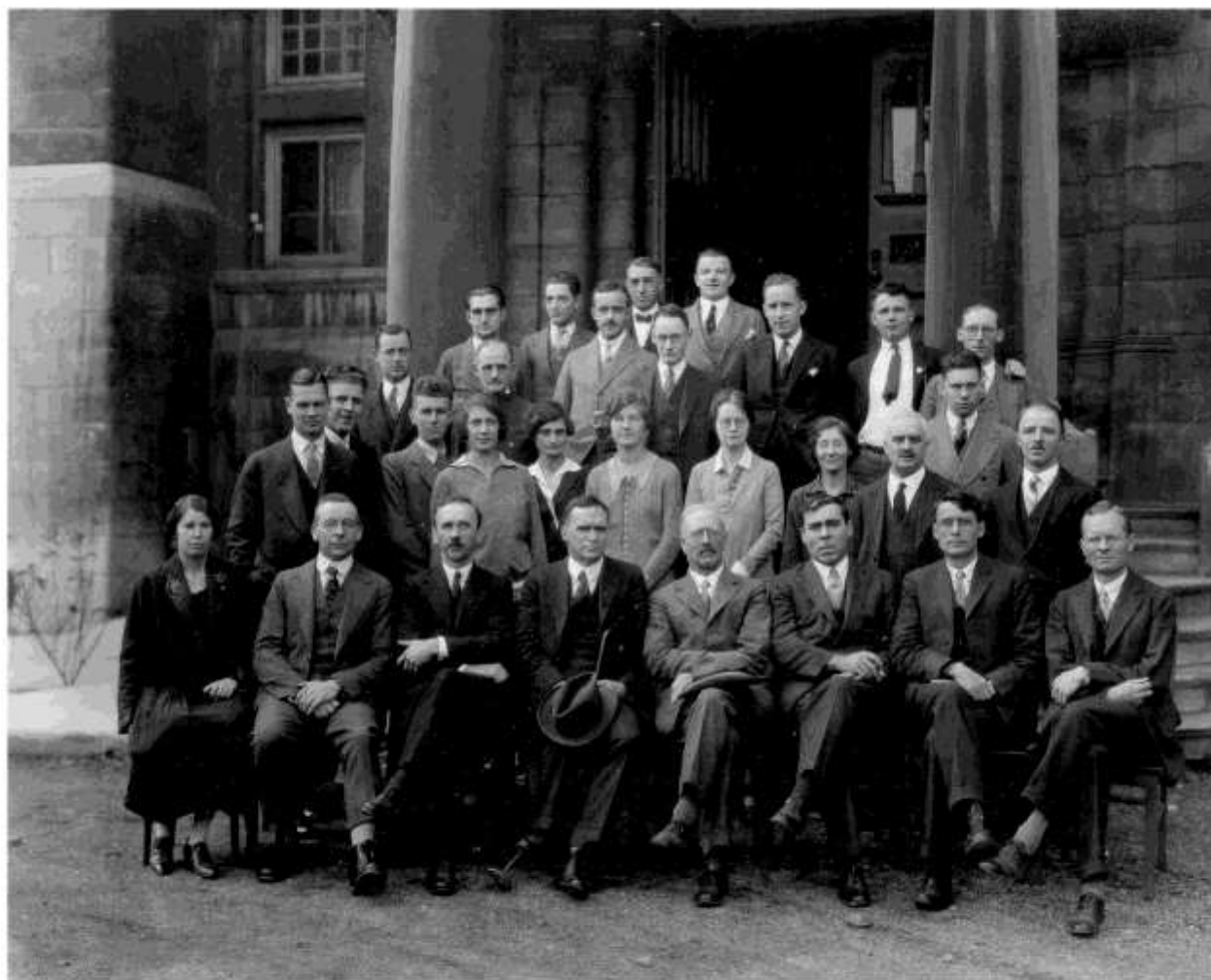

P BOUCHARD L SMITH J SMITH G TWEEDALE
 S AMESSE J PALMER F R TERROUX T N WHITE CH YOUNG F T DAVIES W ROWLES
 A J FLEMING H G WATSON D PRIESTMAN E TRAVERSY L GNAEDINGER L CHALK M CROWE
 C N CAM H T PYE E TAYLOR
 AV DOUGLAS H E REILLEY A N SHAW H T BARNES A S EVE LV KING D A KEYS E S DIELER

1926-1927



T.J.G.Henry - A.J.Ferguson - D.C.Jones
 C.A.Horton - L.R.Walker - F.Panter - E.R.Pounder
 H.Lane - Mrs.Gurd - S.M.Neamtan - F.R.Terroux
 E.Taylor - D.G.Hurst - D.R.M^{rs}Rae - H.T.Pye - S.Giles
 H.G.I.Watson - G.Tweeddale - L.Smith - G.O.Langstroth - W.B.Ross - A.V.Douglas - F.Morgan
 W.H.Watson - J.S.Foster - H.T.Barnes - A.N.Shaw - L.V.King - D.A.Keys - H.E.Reilly
 Not Shown: R.A.Chipman, P.D.P.Smith, S.Amesse, W.H.White

1935-1936

The teaching of physics at McGill University dates from 1854, when the Department of Mathematics and Natural Philosophy was set up within the Faculty of Arts. The calendar for 1857/58 stated that "The Faculty of Arts, as now organized, possesses the means of giving a sound mathematical, classical and scientific education." An Experimental Course was given to 4th year students on Monday, Wednesday and Friday from 3:00 to 4:00 p.m. The course was "...descriptive, illustrated by Diagrams and by Experiments with Philosophical Apparatus, supported, however, by a sufficiency of arguments both inductive and deductive, but the latter divested of Mathematical technicalities." The subjects were: I. The Mechanical Sciences, viz. statics of solids, dynamics of solids, hydrostatics, hydrodynamics; II. Acoustics; III. Optics; IV. Astronomy; V. Electricity (Electrostatics and Electro-Dynamics applied to electricity, regarded as a fluid).

In 1864 Alexander Johnson, LID, was appointed Peter Redpath Professor of Mathematics and Natural Philosophy and, in the same year, the "Anne Molson Gold Medal" was founded by Mrs. John Molson in respect of the Honours Course in Mathematics and Physical Sciences. The student enrolment in McGill University in this academic year was 305, of whom 177 were in Medicine, 48 in Law and 82 in Arts. (Two students were enrolled in two faculties).

In 1889 it was decided to split the Department into separate units of Mathematics (including Mathematical Physics) and Experimental Physics, and

two years later the first Chair of Experimental Physics was endowed by Sir William Macdonald. John Cox, MA, a Fellow of Trinity College, Cambridge, was appointed to this post. The Chair effectively conferred the status of "Department" on Natural Philosophy, although for many years thereafter official publications referred to the Physics Laboratory rather than Department. A second Chair of Natural Philosophy was created in 1894 and this post was filled by Hugh L. Callendar, also a Fellow of Trinity College, Cambridge and former professor of physics at Royal Holloway College in England. The Chair of Mathematics and Mathematical Physics was occupied by G. H. Chandler.

The Macdonald Physics Building

The 1890s were a crucial decade in the development of physics at McGill. When Macdonald endowed the Chair of Experimental Physics in 1891 he also provided generous funds for erecting and equipping a Physics building. Cox was asked to visit laboratories in Europe and America to garner ideas as to the design and furnishing of such a building. Among the Universities visited by Cox in this quest were Harvard, Yale, MIT and Cornell. The architect chosen was Andrew T. Taylor.

The Macdonald Physics building was formally opened on February 24, 1893 by the Governor General of Canada, Lord Stanley. The building was considered to be one of the finest of its kind in North America - perhaps in the world - thanks to Macdonald's "everything of the best" philosophy. It was designed in Romanesque style and

constructed of Montreal limestone lined with pressed brick, and with woodwork in quartered oak. The walls were three feet thick at the base. In order to facilitate experiments in electromagnetism (an important field in the 1890s), some parts of the building, including the magnificent quartered-oak stairway, were constructed entirely without the use of iron. The main entrance hall (now no longer used as such) was provided with an elegant stone fireplace inscribed with the motto, "Prove All Things." The cost of the building, including equipment, was £29,000 (\$145,000), i.e. about 23¢ a cubic foot¹.

An article in *Nature* on "Physics and Engineering at the McGill University, Montreal, published in 1894², stated that the Physics Building "...has been designed for the teaching and study of physics (including mechanics) with special regard to: (1) its intrinsic importance as an integral part of a liberal education in the Faculty of Arts; (2) its essential necessity as a study preliminary to the courses of engineering, mining, and practical chemistry in the Faculty of Applied Science; and (3) the prosecution of scientific research." It will be noted that the objectives of the Physics Building did not include the training of professional physicists, since this profession was virtually non-existent in Canada at that time.

Early Physics Research

Although Cox was "keenly interested in all developments of physics, [he] had not the practical training requisite for research in experimental physics, but devoted himself to the teaching and

administrative side."³ However, research was undertaken by Callendar and a small group of demonstrators (especially Howard Barnes) and graduate students. Callendar specialized in high-precision measurements of thermal quantities, and his platinum-resistance thermometer became accepted as the standard for the measurement of temperature.⁴ In 1899-1900 Callendar and Barnes used the thermometer to measure the variation in the specific heat of water between 0° and 100° C.(Fig.1) They reported a variation of $\pm 0.5\%$, with the minimum value (0.995) at 40°C.⁵ Barnes later extended this research to measure the specific heat of supercooled water.⁶ He also modified the platinum-resistance thermometer for purposes of continuous-flow calorimetry.⁷

Barnes was appointed a lecturer in physics in 1900, assistant professor in 1901 and associate professor in 1906. During this period he began to study the physical and chemical properties of ice, both in the laboratory and in the St. Lawrence River, where he discovered a form of natural ice, called frazil, which can rapidly precipitate ice jams. In 1906 he published an important paper on ice formation⁸, together with a book on the same topic.⁹ Barnes' interest in ice continued for the rest of his career, with papers on the crushing strength and expansive force of ice (1914)^{10 a, b}, and on the physical properties of icebergs (1927).¹¹ His book on "Ice Engineering" was published in 1928.¹²

Rutherford at McGill

In 1898 Callendar resigned his chair at McGill and returned to England as Quain professor of physics at University

College, London. The Chairman of the McGill Physics Department, John Cox, went over to England to seek a replacement and the Cavendish Professor of Physics at Cambridge, J.J. Thomson, recommended a young graduate student from New Zealand, Ernest Rutherford. At first Rutherford was reluctant to accept, but the prospect of a Full Professorship, plus an attractive salary and a well-equipped laboratory, soon persuaded him of the advantages of a period in Montreal, although it is doubtful that he intended to stay as long as 8 1/2 years (September 1898 - March 1907).

During his stay in Montreal, Rutherford published 69 papers, totaling over 700 pages, on the newly-discovered phenomenon of radioactivity. At Cambridge Rutherford had carried out research on ionization in gases and he continued this work at McGill.¹³ However, his emphasis soon shifted from ionization per se to the ionizing radiation emitted by radioactive substances, and hence to the overall study of radioactivity. At first he worked with compounds of thorium, since this was the only radioactive element available in Canada at the time, and observed both the emission of thorium emanation¹⁴ and the phenomenon of "excited radioactivity."¹⁵ As soon as a sample of radium became available, he studied the emanation (radon) produced continuously by this element¹⁶, with the help of a graduate student, Harriet Brooks. Brooks was an unusual phenomenon at that time: a female graduate physicist. A biography of Harriet Brooks was published in 1992.¹⁷

In October 1901 Rutherford was joined in his research by a young English

chemist, Frederick Soddy, who had been appointed as a Demonstrator in the McGill Department of Chemistry. This collaboration lasted 18 months and resulted in eight major papers, including, "The radioactivity of thorium compounds"¹⁸, "The cause and nature of radioactivity"¹⁹, and "Radioactivity change."²⁰ These papers enunciated the Transformation Theory of Radioactivity, which was soon accepted by the scientific community. The apparatus used by Rutherford and Soddy in 1902 to measure the emanating power of different substances is shown in Fig.2.¹⁹ The Rutherford-Soddy collaboration at McGill is acknowledged as one of the most important partnerships in the history of science. A detailed study of the collaboration was published in 1977²¹, and a paper on the same theme in 1997.²²

Apart from his collaborative research with Soddy, in 1902-03 Rutherford made a number of other studies of radioactive phenomena, including the properties of the "deviable rays," i.e. β -rays, emitted by radioactive substances²³ and excited radioactivity.²⁴ He also demonstrated, for the first time, that the "easily absorbed rays," i.e. alpha-rays, from radium could be deviated in a magnetic or electric field.²⁵ This was the first proof that the α -rays were positively charged particles and was an important step in ascertaining their nature as doubly-charged atoms of helium.

Rutherford's research in 1904 related to two different aspects of radioactivity: the energy (heat) released in a radioactive transformation (in collaboration with Barnes)²⁶; and elucidation of the uranium-radium radioactive series.^{27, 28}

His last work at McGill, in 1905-06, concentrated on the nature and properties of the α -particle,²⁹⁻³² (Fig. 3) although it was not until 1908, in Manchester, that he was able to prove its nature conclusively, by demonstrating the spectrum of helium.^{33,34}

Rutherford moved from Montreal to Manchester in the summer of 1907, and the following year he was awarded the Nobel Prize in Chemistry for "researches on the disintegration of the elements and the chemistry of radioactive matter." Although he was no longer in Montreal, most of the work referred to in this citation had been carried out during his 9-year tenure at McGill. Rutherford delivered his Nobel Lecture in Stockholm on December 11, 1908, under the title, "The Chemical Nature of the α -Particle from Radioactive Substances."³⁵

Rutherford's Research Team

By 1903 Rutherford's international reputation was sufficient to attract graduate students and post-doctoral scientists from outside Canada. These workers carried out research projects suggested by Rutherford and under his general guidance, but the results were almost always published alone. Rutherford's team included Arthur Stewart Eve from England, Fanny Cook Gates and Howard Bronson from the U.S., Otto Hahn and Max Levin from Germany and Tadeusz Godlewski from Poland. In the period 1904-07 these scientists published over 30 independent research papers on various aspects of radioactivity, although, as Pyenson has pointed out³⁶, Rutherford failed to establish a

permanent "research school" at McGill.

In 1904 Eve showed that gamma rays are an extremely penetrating type of Röntgen ray - a fact previously suspected but unproven.³⁷ The following year Eve undertook a detailed investigation of the absorption in lead of the γ rays from compounds of uranium, radium, thorium and actinium, and was thereby able to prove that the γ rays provide an accurate means of assaying the radioactivity of any source.³⁸ He then applied the method in a series of measurements of the radioactivity of air, water and minerals.³⁹⁻⁴² Eve concluded that the ionization measured in the atmosphere is due mainly to the α -rays emitted by atmospheric emanation, but a small fraction (about 6%) is due to penetrating radiation from radium present in the earth's crust.⁴⁰ (However, the existence of cosmic radiation was unknown at the time). By absorbing atmospheric emanation (radon) in charcoal, Eve concluded that an average relative concentration of 8×10^{-11} radium in the earth's crust was sufficient to maintain the measured value of emanation in the atmosphere, and this agrees with the incidence of radium C in rocks found in the earth's crust.⁴²

Fanny Cook Gates, of Baltimore, spent a year with Rutherford in 1902-03. She studied the effect of heat on excited radioactivity and determined that the activity (i.e. radioactive particles) is not destroyed but merely transferred to nearby cooler surfaces.⁴³

Howard L. Bronson, a young American research student, came to McGill in 1904 and rose to the rank of Assistant Professor in 1909-11. He published five

papers on various aspects of radioactivity, beginning in 1905 with an instrument for measuring radioactivity by a constant deflection method.⁴⁴ Examples of decay curves measured by Bronson with this instrument are shown in Fig. 4. Up to that time the standard method of measuring an ionization current was to observe the rate of movement of a quadrant electrometer connected to the ionization chamber, a method which was inconvenient and could not be used when the ionization current was changing rapidly. Bronson's instrument was modified and improved in 1907 by S.J. Allen.⁴⁵ Bronson used the constant deflection method in several determinations of the rate of decay of radioactive elements, particularly where a radioactive series involves the simultaneous decay of two or more components.^{44, 46} He investigated the effect of temperature on the rate of decay in the range -180° to 1600°C , and concluded that any change in this rate "cannot be over 1 per cent" and therefore radioactivity is unaffected by temperature.⁴⁷

Bronson carried out two other important investigations under Rutherford's guidance. These concerned the ionization produced by an α -particle near the end of its range,⁴⁸ and elucidation of the section of the radium decay series involving radium A (half-life 3 min), B (26 min) and C (19 min).⁴⁹

The most distinguished overseas member of Rutherford's research team at McGill was the German physical-chemist, Otto Hahn. Hahn spent a year at McGill, 1905-06, during which period he published three papers. Two of these papers were concerned with the active deposit arising from

radiothorium and its gaseous product, thorium emanation.^{50, 51} Hahn found that two α -ray products are present in the active deposit of radiothorium and not one, as was previously supposed. Hahn's third McGill paper was essentially a continuation of the previous studies but dealt with the products of actinium rather than thorium.⁵²

Another German physical chemist who spent the year 1905-06 with Rutherford was Max Levin. Levin carried out three investigations at McGill, relating to the origin of the α rays emitted by thorium and actinium,⁵³ the properties of actinium⁵⁴ and the properties of the α rays from polonium.⁵⁵ After Levin's departure from McGill, his place was taken by his brother-in-law, Gustav Rümelin, who undertook a new measurement of the half-life of radium emanation (Ra-222, radon). His result, 3.75 days, was close to today's value of 3.82 days.⁵⁶

Another member of Rutherford's research team was Tadeusz Godlewski, from Cracow in Poland, who arrived in Montreal in the autumn of 1904, and immediately began work on problems relating to the radioactivity of actinium and uranium. Godlewski separated the "active substance" from actinium and named this component actinium X, by analogy with uranium X and thorium X.⁵⁷ Godlewski's second investigation related to uranium and its product uranium-X,⁵⁸ and his third, and final, paper at McGill was concerned with the properties of the β and γ rays of actinium.⁵⁹

The work of both Rutherford himself and the members of his research team at

McGill has been discussed in more detail in a recent paper under the title "Rutherford's Curriculum Vitae, 1894-1907".⁶⁰

Physics Staff and Teaching, 1907-21

In the academic year 1906-07, the staff of the Physics Department comprised two professors (Cox and Rutherford), one associate professor (Barnes) and three demonstrators (R.K. McClung, H.L. Bronson and R.W. Boyle). Apart from their teaching to "non-physics" students (arts, medicine, engineering), as previously indicated, there was a "Special course for graduates and advanced students." This comprised: (i) the relationship of optics and electricity (Cox); (ii) processes occurring in radioactive elements (Rutherford); (iii) electrical standards (Barnes); and (iv) applied mathematics (Tory, in the Maths Dept.).

During the next 15 years the Physics staff grew slowly, but with considerable fluctuations. Thus, by 1910-11 the staff had expanded to 11, comprising two professors, one assistant professor, 3 lecturers and 5 demonstrators. This number shrunk to 9 in 1912-13, and to 8 in 1915-17. In practice the 1917 staff was only six, since two members were on leave for military service. When the war ended the staff increased rapidly and, by 1920-21, had risen to 11, comprising one professor, two associate professors, two assistant professors and six demonstrators.

Under the heading "Physics Building Committee," the annual report of McGill University for 1907-08 noted that: "Lectures and laboratory work in Physics for 1st year medicine will be

given by the Department of Physics in the Physics Building. Thus, for the first time, the whole of Physics teaching in the University will be given under one roof by the same staff. The entry of 200 in 1st year Applied Science involves duplicating lectures and quadrupling laboratory sections." It will be noted that the term "Department of Physics" was used although it was not until the following year (1908-09) that the annual report listed the "Physics Department" as such.

Cox retired in 1909 and Howard Barnes was appointed Departmental Head. Barnes had earlier (1907) been appointed Macdonald Professor of Physics, following the resignation of Rutherford. He held these posts until 1919, when he was forced to resign because of a nervous breakdown. However, by 1923 he was able to resume his research and, in 1924, regained the title of professor. As previously noted, his book on "Ice Engineering" was published in 1928¹². Meanwhile, in 1919, Stewart Eve was appointed Director of the Physics Department, a post he held until his retirement in 1935.

The Department of Physics in World-War I

During the War of 1914-18 the McGill Physics Department was actively engaged in research connected with the war effort. The Director, Dr. H.T. Barnes, assisted the Militia Department in examining and reporting on several inventions and Dr. L. V. King undertook special work on submarine acoustics for the British Board of Inventions and Research. Drs. Eve and Gray were

both away on active service. In 1917 Eve was promoted to the rank of Colonel in the British Army and was appointed Director of the Admiralty Station at Harwich in England.

The Annual Report for 1918-19 noted that there were increasing complaints that the Macdonald Physics Building was inadequate: "...it has neither an elementary lab nor lecture accommodation for large numbers." Various proposals were made to remedy this situation, including the erection of a new Physics Building, but it was over 50 years before the latter proposal was actually carried out.

Physics Research, 1908-19

Rutherford's departure from McGill in 1907 did not signal the end of departmental research relating to radiation, radioactivity and ionization. Eve, in particular, continued to investigate various aspects of these phenomena. (Eve's official title at that time was "Associate Professor of Mathematics and Lecturer in Radioactivity.") In 1908 he published papers on the effect of an electric field on the α , β and secondary rays from radioactive substances,⁶¹ on the radium emanation in the atmosphere,⁶² and on secondary rays.⁶³ In the first of these papers,⁶¹ Eve showed that the intensity of "secondary" radiation induced by the β and α rays of radium is a function of the atomic weight of the absorbing material, although at this stage it was unclear whether the secondary radiation is scattered primary or radiation induced by the interaction of the primary rays with atoms of matter. (Indeed, the nature of the α rays was

still uncertain. Eve stated: "...we will suppose them to be aether pulses.") Eve published a further paper on this problem in 1909,⁶⁴ but the nature of the interaction processes between matter and X- and γ - radiation was not clarified until the work of Gray in 1913-22 and Compton in 1923 (see below).

In 1909 Eve investigated the radium present in sea-water,⁶⁵ and in the following year he published a detailed investigation of the effect of dust and smoke on the ionization of air (Fig.5).⁶⁶ He reported that the number of ions detected with a constant source of α rays, and a constant air current to the testing vessel, is strongly dependent on the purity of the atmosphere with respect to dust, smoke and mist. In 1914 Eve measured the number of ions produced by the penetrating γ radiation from 1 gram of radium in equilibrium with its decay products. He obtained the value 8.4×10^{14} , in good agreement with previous determinations.⁶⁷ This was Eve's last paper before volunteering for military service in the 1914-18 war.

In 1909 Barnes published two papers on topics not related to his research on ice which was discussed earlier.⁽⁸⁻¹²⁾ The new work was concerned with: (a) the discharge of electricity from pointed conductors;⁶⁸ and (b) the absolute value of the mechanical equivalent of heat.⁶⁹ Barnes' new measured value for the 15°C calorie was 4.184 joules. (The calorie is now defined as exactly 4.186 J.) In 1914 Barnes investigated the so-called "Dawson isothermal layer" in the Gulf of St. Lawrence.⁷⁰ This is a layer of salt water at a depth of about 30 or 40 fathoms, the temperature of which remains fairly constant the year round at about 30°F, while at a greater depth the

temperature rises to approximately 34°F and at higher levels the temperature changes with the seasons. (The freezing point of salt water is 28°F.) The following year Barnes investigated the effect of strain on the expansion of quartz.⁷¹

Louis Vessot King was appointed a Sessional Lecturer in Physics in 1911 and promoted to Assistant Professor in 1912 and Associate Professor in 1915. During the years 1911-1919 he carried out extensive research on both radiation and non-radiation topics; his published papers in this period include the investigation of absorption problems in radioactivity (1911),⁷² the scattering and absorption of light in gaseous media (1912),⁷³ penetrating radiation from the Earth (1913),⁷⁴ Avogadro's number and the electronic charge (1914),⁷⁵ the measurement of air velocity (1915),⁷⁶ the density of molecules in interstellar space (1915),⁷⁷ and the electrical and acoustic characteristics of telephone receivers (1919).⁷⁸ The sonometer described by King in the last paper, for the precision measurement of frequency in the range 360 to 1600 cps, is shown in Fig. 6.

Harold A. Wilson published several important papers in the period 1910-11, covering the statistical theory of heat radiation,⁷⁹ the electron theory of the optical properties of metals,⁸⁰ the velocity of the ions of alkali salt vapours in flames,⁸¹ and the number of electrons in the atom.^{82,83} The latter paper assumed J.J. Thomson's 1907 model of the atom, i.e. a rigid sphere of positive electricity containing negative electrons which can move freely inside the positive charge.

In the period 1907-11 R.W. Boyle, an

1851 Exhibition Science Scholar at McGill, published several papers on the properties of thorium and radium emanations. These included studies of the absorption of radioactive emanations by charcoal,⁸⁴⁻⁸⁶ and the behavior of these emanations at low temperatures.^{87, 88}

Joseph A. Gray was an Australian physicist who had worked with Rutherford in Manchester as an 1851 Exhibition Scholar. In this capacity he showed that primary γ -rays are essentially the same as X rays: up to this time the nature of the γ -rays was controversial.⁸⁹ In 1913 Gray moved to Montreal as a Lecturer in Physics at McGill, and he was promoted to Assistant Professor in 1915 and to Associate Professor in 1919. In October 1913 he reported that scattered γ rays are less penetrating than the primary rays, the change being greater as the angle of scattering increases and dependent also on the nature of the scattering medium.⁹⁰ This was followed in 1914 by a study of the γ rays excited in lead by the β -rays of Radium E.⁹¹ (Nowadays we would refer to the radiation excited by β -ray (i.e. electron) bombardment as X-rays rather than γ -rays.) During WW-I Gray volunteered for military service and there is a gap in his science output until 1920, when he published a detailed study of the scattering of X- and γ -rays.⁹² In this paper he stated that "...the scattering of X-rays is not as simple a process as has generally been believed.....a great deal of work needs to be done before we can properly understand the problem." Some of the absorption curves included in this paper, for primary and scattered X-rays, are shown in Fig. 7. Gray published two shorter papers on the

same topic in 1922-23,^{93, 94} and in 1924 he moved to Queen's University as Chown Research Professor of Physics.

The effect discovered by Gray in 1913 was re-investigated 10 years later by Arthur Compton, who quantified the effect by applying Quantum Theory.⁹⁵ The process is now known as "Compton scattering" and Gray's role in the discovery is virtually forgotten. Indeed, as W.B. Lewis noted in 1967, in the official "Biographical Memoir" of Gray published by the Royal Society,⁹⁶ "A more just and precise world would have named the effect after Gray and the identified process after Compton.... Gray had laboured and built the staircase on which Compton had laid the carpet."

In 1915 Norman Shaw, an Associate Professor of Physics at Macdonald College, investigated the secondary electrons generated by a primary stream of cathode rays (electrons) in the residual gas inside a "vacuum" tube.⁹⁷ The apparatus used by Shaw for this work is shown in Fig. 8. In 1919 Shaw, together with a graduate student, Violet Henry, carried out an analysis of estuary tides by a projection method.⁹⁸ This is a complex situation, since in the open coast of the ocean the tide consists of a fairly symmetrical undulation, but when this undulation enters an estuary it is opposed by the outflow of the river. Shaw published two other papers in 1919, on the characteristic constants of small magnets,⁹⁹ and (with a graduate student, H.E. Reilley) on the effect of aging in Weston cells.¹⁰⁰ (Shaw had meanwhile moved to the main Physics Department on the downtown campus.)

Several other papers published in the

period 1908-19 need to be mentioned. In 1908 Howard L. Bronson, a Lecturer in Physics, investigated the construction and calibration of very high resistances.¹⁰¹ The following year he studied the α rays emitted by radium-B,¹⁰² and (in collaboration with Shaw), the reproducibility of Clark and Weston cells.¹⁰³ The latter paper also included a recalculation of the mechanical equivalent of heat. In 1914 N.E. Wheeler, a Lecturer in Physics, measured the thermal expansion of vitreous quartz (fused silica), the importance of which derives from the use of this material in thermometry and in the construction of standards of length.¹⁰⁴ In the same year C.B. James, a Demonstrator in Physics, determined the coefficient of expansion of mercury at low temperatures, using the apparatus shown in Fig. 9.¹⁰⁵ In 1915 J. Moran carried out a comparison of the Rutherford-Boltwood standard radium solution at McGill with the so-called Washington standard.¹⁰⁶ The measurements indicated that the "strong" and "weak" solutions of the Rutherford-Boltwood standard, prepared in the ratio 100:1, agreed within about 2%.

The McGill Ph.D. Degree

McGill University instituted a Ph.D. degree for research in 1906/07. In that academic year there were 7 candidates, of whom one was a Physics student. The number of candidates rose steadily year by year, reaching 24 for the University as a whole in 1911/12, of whom 5 were registered in the Physics Department. Subsequently the number decreased, especially during the war years, with a low of 8 candidates in the University in 1917/18, of whom 2 were

students of Physics.

The Physics Department Between the Two Wars

At the end of WW-I the academic staff of the McGill Physics Department numbered seven, comprising 2 professors, 2 associate professors and 3 assistant professors. In practice there were only 5 members of the Physics Faculty, since 2 were absent on military service. In addition there were a number of demonstrators, but they did not rank as Faculty.

During the next decade the Faculty increased slowly, to 9 in 1925-26 and 11 in 1930-31. The latter number comprised 5 professors, including the Departmental Director, 3 associate professors and 3 lecturers. After 1931 the Faculty decreased to 10 in 1932-33 and 9 in 1935-36, and remained at the latter level until the outbreak of WW-II in 1939.

As previously stated, Howard Barnes resigned from the Chair of the Department in 1919 and his place was taken by Arthur Stewart Eve, who held the post until his retirement in 1935. Eve was succeeded by Norman Shaw, Director of the Department until 1951.

The annual Report of McGill University for 1920-21 noted that 923 students, including 44 Graduate and Honor students, attended courses in the Physics Department, for a total of 4,244 student-hours. Two years later (1922-23) the report stated that "This rapid growth [of Physics and Chemistry] necessitates a review of the changes advisable in the instruction given in

Universities and schools, and in the research work which should be organized for industrial and commercial purposes as well as for the advancement of knowledge...the essential prerequisite subject of Mathematics is not taught today better than it was 25 years ago...in Engineering and in Medicine it is now agreed that the training in Physics in the first two years is attended with mental dyspepsia.... These considerations suggest careful revision of curricula....."

The number of students enrolled in Physics courses - not necessarily Physics students per se - appears to have decreased in the inter-war years. The Annual Report for 1926-27 gave the number attending Physics courses as "more than 600 students from 7 faculties," and the 1936-37 Report quoted the enrolment as 537, of whom 2 were registered in Physics M.Sc. programs and 9 in Physics Ph.D. programs. In the latter year (1936-37), 5 Physics Ph.D.'s were awarded. As will be noted later in this report, the number of students registered in graduate programs fell during the war years, reaching zero in 1941-42, but increased rapidly at the end of the war to levels far above those in the inter-war period.

An important milestone was passed in 1928, when Laura Rowles (née Chalk) was the first woman to obtain a Ph.D. in physics from McGill University. Dr. Rowles died in 1996.

An interesting innovation in the 1920s (the precise year has not been ascertained) was a series of Christmas "Lectures for Boys and Girls." The poster for the 1927 series is shown in Fig. 10.

Physics Research Between the Wars

Physics research at McGill in the 1920s and 30s was dominated by five names: King, Shaw, Foster, Douglas and Watson. Louis Vessot King was promoted to a Full Professorship in 1920 and at the same time appointed Macdonald Professor of Physics. In 1921 he investigated the acoustic characteristics of an electric sound generator/receiver for submarines.¹⁰⁷ He found that the apparatus would not radiate efficiently at a given frequency unless the effective diameter was of the correct size and the fundamental pitch very close to the frequency of the applied alternating voltage. Furthermore, there is a need for continuously altering the pitch of submarine sound-generators or receivers. The tunable diaphragm designed by King is shown in Fig. 11 (a), and the submarine microphone receiver fitted with such a diaphragm is illustrated in Fig. 11 (b). The following year he reported some new formulae for the calculation of the mutual induction of coaxial circles,¹⁰⁸ and in 1923 he investigated the molecules of gaseous and liquid media in which light is scattered and dispersed.¹⁰⁹ King remained active throughout the 1920s and 1930s. His later work included the protection of parts of the circuit of a radio receiving apparatus from the disturbing effect of electromagnetic fields,¹¹⁰ problems related to the design of piezo- electric oscillators,¹¹¹ the acoustic properties of circular discs,^{112,}¹¹³ the electrical and acoustic conductivities of cylindrical tubes,¹¹⁴ and the radiation characteristics of a vertical antenna for radio-broadcasting.¹¹⁵

Professor Norman Shaw published a number of papers in the period 1924-35, mainly (but not exclusively) in the field of thermodynamics. In 1924 he discussed the phenomenon of "heavy ice," i.e. an abnormal and rare form of ice that is denser than water.¹¹⁶ In 1930 Shaw, with Associate Professor H.G. Reilley, investigated the problems involved in the maintenance of a standard of electromotive force to within one or two parts per million, via the construction and maintenance of Weston standard cells.¹¹⁷ In 1932 he reported on the rapid derivation of thermodynamical relations¹¹⁸ and, in the same year, Arthur Snell, a graduate student working under Shaw, developed a new method for comparing gaseous densities at any ordinary pressure.¹¹⁹ This technique involved the balancing of columns 12 m in height, using a modified Toepler micromanometer as shown in Fig. 12. The sensitivity of the method was 10^{-7} g/cc. In 1935 Shaw published a major paper on the derivation of thermodynamical relations.¹²⁰ In this work he developed a procedure for rapidly expressing any first or second partial derivative, relating to a simple substance, in terms of any permissible set of "reference derivatives." The method enabled compact tables of thermodynamical relations to be derived simply and systematically. Applications of the method to special cases were also discussed.

John Stewart Foster rose from Assistant Professor of Physics in 1924 to Macdonald Professor of Physics in 1936 and Rutherford Professor of Physics in 1955. As will be noted later, he was Director of the Radiation Laboratory and Cyclotron from 1947 until his retirement

in 1960. During the period under review in this section, 1919-39, Foster's main interest was the Stark effect, i.e. the splitting of spectral lines under the influence of a strong electric field. His first paper on this topic, in which he discussed the Stark effect in hydrogen and helium, was published in 1924, when he was a Research Fellow at Yale.¹²¹ Letters to Nature on the effect followed in 1925-26,¹²²⁻¹²⁴ and a paper on Stark patterns in helium in 1927.¹²⁵ In 1926-27 Foster undertook post-doctoral work with Niels Bohr in Copenhagen, and a major paper resulted on the application of Quantum Mechanics to the Stark effect.¹²⁶ In 1929-31 he published a series of papers on the effect in hydrogen,¹²⁷ neon¹²⁸ and helium.¹²⁹ The latter paper, published in two parts in 1929 and 1931, discussed the effect on the helium spectrum of combined electric and magnetic fields. The magnetic separation of the lines in a helium spectrum were found to be independent of the Stark (electric) effect. A further study of the Stark effect in hydrogen was published in 1929 by MacDonald, a research student working under Foster.¹³⁰

Foster's interest in the Stark effect continued through the 1930s. In 1934 he published letters in Nature relating to the effect for helium lines in the spectra of β stars¹³¹ and hydrogen isotopes.¹³² The splitting of the lines for a mixture of hydrogen isotopes H^1 and H^2 , in fields up to 52 kV/cm, is illustrated in Fig. 13. In this investigation Foster was assisted by Hawley Snell, a Research Associate who published an independent paper in 1935 on the Stark effect in the molecular spectrum of hydrogen.¹³³ A further joint paper by Foster and Snell on the Stark effect in hydrogen and deuterium

followed in 1937.¹³⁴ In the same year Panter, a Demonstrator in Physics, and Foster discussed the Stark effect in iron,¹³⁵ and in 1938 Foster and Horton (also a Demonstrator in Physics) investigated the effect in argon and krypton.¹³⁶ In 1939 Foster and Vibert Douglas, a member of the Physics Faculty who specialized in astrophysics (see below) published a joint paper on the Stark effect in β stars.¹³⁷ In 1939 Foster also published a review paper on "The Stark effect and some related phenomena."¹³⁸

In 1935 Foster, together with two research associates, published a paper not related to the Stark effect, but concerned with the quantitative spectrographic analysis of biological material: the determination of lead in cerebrospinal fluid.¹³⁹

Alice Vibert Douglas was an astrophysicist and a member of the McGill Physics Faculty from 1923 to 1939. During this period she published extensively, both in scientific and popular journals, mainly but not exclusively on various aspects of astronomy. Her non-astronomy papers in 1922-24 included measurements of the effective range of the β -rays from radium E,¹⁴⁰ the interpretation of the Wegener frequency curve relating to continental drift,¹⁴¹ and the ionization clouds produced by a point discharge in an expansion chamber.¹⁴² Douglas was unable to obtain photographs of these clouds - extremely short exposures were needed - but she made drawings of the typical features: Fig. 14. Douglas' papers on astronomy include discussions of the winter and summer sky,^{143, 144} spectroscopic and other measurements of stars,¹⁴⁵⁻¹⁴⁹ a report

on the 1932 total solar eclipse,¹⁵⁰ and information on stars¹⁵¹ and meteors.¹⁵² In 1939 Douglas was appointed Dean of Women at Queen's University.

W.H. Watson was an Assistant Professor of Physics in the 1930s and was promoted to Associate Professor at the end of the decade. His research involved several branches of physics, including optics, electromagnetism and dynamics. In two papers^{154, 157} and a letter to Nature¹⁵⁸ in the period 1934-36, Watson investigated the absorption in alkali metal films of U.V. radiation in the so-called Schumann region, i.e. 1000-2000 Angstroms. He deposited transparent films of sodium and potassium on fluorite cooled to liquid air temperature and photographed the spectrum of transmitted light. In this way he determined that sodium transmits down to 1250Å (the limit of fluorite) while potassium transmits down to 1400Å. In another group of papers Watson discussed the interaction and relationship of electrostatic, electromagnetic and so-called momentum fields.^{153, 156, 159-161} In a paper published in 1935 he described an a-c. bridge for the measurement of small capacities in the range 1-1000 micro-micro-farads.¹⁵⁵

Among the other publications of the Physics Department in the inter-war years were those of David Keys, and in particular a 1923 paper on the cathode-ray oscillograph and its applications.¹⁶² A diagram of the oscillograph is shown in Fig. 15. The

author pointed out that "This oscillograph has made it possible to measure changes in pressure or potential which occur in a hundred-thousandth of a second or less." Other papers by Keys in this period related to the piezo-electric constants of tourmaline¹⁶³ and the striated electrical discharge in gases.¹⁶⁴

In 1935 G.O. Langstroth, a Research Associate in the Physics Department, investigated the intensities of the nitrogen bands in the spectrum excited by electrons of energies between 14 and 160 eV.¹⁶⁵ The relative intensities of 12 bands were found to be independent of the accelerating potential above 30 volts. Two years later, together with D.R. McRae (also a Research Associate), Langstroth developed a multi-step absorption filter based on thin films of antimony which are spectroscopically nearly neutral for wavelengths below 4000 Å.U.¹⁶⁶ Langstroth and McRae published two further joint papers in 1938, both on sources for spectroscopic analysis.^{167, 168}

Finally two short publications by Eve must be mentioned. (As stated previously, Eve was appointed Chairman of the Physics Department in 1919 and remained in this position until his retirement in 1935.) In 1921 Eve published a letter in Nature on ionization potential and the size of the atom,¹⁶⁹ and a "Note on missing spectra" in the Physical Review.¹⁷⁰

REFERENCES

1. Eve, AS. Some Scientific Centres. VIII. The Macdonald Physics Building, McGill University, Montreal. *Nature*, 74, 272-275, July 19, 1906.
2. Physics and Engineering at the McGill University, Montreal. (Unsigned). *Nature*, 50, 558-564, Oct. 4, 1894.
3. Obituary: Professor John Cox. *Nature*, III, 817, June 16, 1923. (Unsigned, but believed to have been written by Rutherford.)
4. Callendar, HL.
 - a. Proposals for a standard scale of temperature on the platinum resistance thermometer. *British Assoc. Reports*, 242-243, 1898;
 - b. Notes on platinum thermometry. *Phil. Mag.*, 47, 191-222 (1899);
 - c. On a practical thermometric standard. *Phil. Mag.*, 48, 519-547 (1899).
5. Callendar, HL, Barnes, HT. Note on the variation of the specific heat of water between 0° and 100°C. *Phys. Rev.*, 10, 202-214 (1900).
6. Barnes, HT, Cooke, HL. On the specific heat of supercooled water. *Phys. Rev.*, 15, 65-72 (1902).
7. Barnes, HT, McIntosh, D. A new form of platinum resistance- thermometer, specially adapted for the continuous flow calorimeter. *Phil. Mag.*, ser. 6, 6, 350-352 (1903).
8. Barnes, HT. Anchor ice formation from the standpoint of the radiation theory. *Trans. Roy. Soc. Can. ser. 2*, 12, sec. iii, 65-109 (1906).
9. Barnes, HT. "Ice Formation, with Special Reference to Anchor Ice and Frazil." (New York, John Wiley & Sons, 1906).
10. (a) Barnes, HT. The crushing strength of ice. *Trans. Roy. Soc. Can.*, ser. 3, 8, sec. iii, 19-22 (1914) and (with Mackay, HM) 9, 87-92 (1915).
10. (b) Barnes, HT. Hayward JW, McLeod NM. The expansive force of ice. *Trans. Roy. Soc. Can.*, ser. 3, 8, sec. iii, 29-49 (1914).
11. Barnes, HT. Physical properties of icebergs. *Proc. Roy. Soc. A*, 114, 161 (1927).
12. Barnes, HT. "Ice Engineering." (Montreal: Renouf Publishing Co., 1928).
13. Rutherford, E, McClung, RK. Energy of Röntgen and Becquerel rays, and the energy required to produce an ion in gases. *Phil. Trans. Roy. Soc.*, ser. A, 196, 25-59 (1901).
14. Rutherford, E. A radioactive substance emitted from thorium compounds. *Phil. Mag.*, ser. 5, 49, 1-14 (1900).
15. Rutherford, E. Radioactivity produced in substances by the action of thorium compounds. *Phil. Mag.*, ser. 5, 49, 161-192 (1900).
16. Rutherford, E, Brooks, HT. The new gas from radium. *Trans. Roy. Soc. Can.*, sec. iii, ser. ii, 7, 21-25 (1901).

17. Rayner-Canham, MF, Rayner-Canham, GW. "Harriet Brooks: Pioneer Nuclear Scientist." (Montreal: McGill-Queen's University Press, 1991). and Am.. J. Phys. 57, 899-902 (1989).
18. Rutherford, E, Soddy, F. The radioactivity of thorium compounds. Trans. Chem. Soc. 81, 321-350 and 837-860 (1902).
19. Rutherford, E, Soddy F. The cause and nature of radioactivity. Phil. Mag., ser. 6, 4, 370-396 and 569-585 (1902).
20. Rutherford, E, Soddy, F. Radioactive Change. Phil. Mag., ser. 6, 5, 576-591 (1903).
21. Trenn, TJ. "The Self-splitting Atom. The History of the Rutherford-Soddy Collaboration." (London: Taylor & Frances, Ltd., 1977).
22. Cohen, M. Ernest Rutherford and Frederick Soddy: An historic partnership. The Chemical Intelligencer, April 1997, 33- 40.
23. Rutherford, E, Grier, AG. Deviable rays of radioactive substances. Phil. Mag., ser. 6, 4, 315-330 (1902).
24. Rutherford, E. Excited radioactivity and the method of its transmission. Phil. Mag., ser. 6, 5, 95-117 (1903).
25. Rutherford, E. The magnetic and electric deviation of the easily absorbed rays from radium. Phil. Mag., ser. 6, 5, 177-187 (1903).
26. Rutherford, E, Barnes, HT. Heating effect of radium emanation. Phil. Mag., ser. 6, 7, 202-219 (1940).
27. Rutherford, E. Slow transformation products of radium. Phil. Mag., ser. 6, 8, 636-650 (1904).
28. Rutherford, E. The succession of changes in radioactive bodies. Phil. Trans. Roy. Soc., ser. A, 204, 169-219 (1904).
29. Rutherford, E. Some properties of the alpha rays from radium. Phil. Mag., ser. 6, 10, 163-176 (1905).
30. Rutherford, E. Retardation of the alpha particle from radium in passing through matter. Phil. Mag., ser. 6, 12, 134- 146 (1906).
31. Rutherford, E. The mass and velocity of the alpha particles expelled from radium and actinium. Phil. Mag., ser. 6, 12, 348- 371 (1906).
32. Rutherford, E. The velocity and energy of the alpha particles from radioactive substances. Phil. Mag., ser. 6, 13, 110- 117 (1907).
33. Rutherford, E. The nature and charge of the α particles from radioactive substances. Nature, 79, 12-15 (1908).
34. Rutherford, E, Royds, T. The nature of the α particle from radioactive substances. Phil. Mag., ser. 6, 17, 281-286 (1909).
35. Rutherford, E. The chemical nature of the α particles from radioactive substances. Nobel Lecture, Dec. 11, 1908, in "The Collected Papers of Lord Rutherford of Nelson," Vol. II, 137- 146. (London, George Allen and Unwin Ltd. 1963).

36. Pyenson, L. The incomplete transmission of a European image: Physics at Greater Buenos Aires and Montreal, 1890-1920.

37. Eve, AS. A comparison of the ionization in gases by penetrating Röntgen and radium rays. Phil. Mag., ser. 6, 8, 610-618 (1904).

38. Eve, AS. On the absorption of the γ rays of radioactive substances. Phil. Mag., ser. 6, 11, 586-595 (1906).

39. Eve, AS. On the radioactive matter present in the atmosphere. Phil. Mag., ser. 6, 10, 98-112 (1905).

40. Eve, AS. On the radioactive matter in the earth and the atmosphere. Phil. Mag., ser. 6, 12, 189-200 (1906).

41. Eve, AS. The ionization of the atmosphere over the ocean. Phil. Mag., ser. 6, 13, 248-258 (1907).

42. Eve, AS. On the amount of radium emanation in the atmosphere near the earth's surface. Phil. Mag., ser. 6, 14, 724-733 (1907).

43. Gates, FC. Effect of heat on excited radioactivity. Phys. Rev., 16, 300-305 (1903).

44. Bronson, HL. Radioactive measurements by a constant deflection method. Am. J. Sci. 19, 185-187 (1905).

45. Allen, SJ. A null instrument for measuring ionization. Phil. Mag., ser. 6, 14, 712-723 (1907).

46. Bronson, HL. The effect of high temperatures on the rate of decay of the active deposit from radium. Am. J. Sci., 20, 60-64 (1905).

47. Bronson, HL. The effect of high temperature on the activity of radium and its transformation products. Proc. Roy. Soc. A., 78, 494-500 (1907).

48. Bronson, HL. On the ionization produced by α -rays. Phil. Mag., ser. 6, 11, 806-812 (1906).

49. Bronson, HL. On the periods of transformation of radium A, B and C. Phil. Mag., ser. 6, 12, 73-82 (1906).

50. Hahn, O. On the properties of the α -rays from radiothorium (I), Phil. Mag., ser. 6, 11, 793-805 (1906).

51. Hahn, O. On the properties of the α -rays from radiothorium (II), Phil. Mag., ser. 6, 12, 82-93 (1906).

52. Hahn, O. The ionization ranges of the α -rays of actinium. Phil. Mag., ser. 6, 12, 244-254 (1906).

53. Levin, M. On the origin of the β -rays emitted by thorium and actinium. Phil. Mag., ser. 6, 12, 177-188 (1906).

54. Levin, M. Einige Eigenschaften des Aktiniums. Phys. Zeit., 7, 812-815 (1906)

55. Levin, M. On the absorption of the α -rays from polonium. Am. J. Sci., ser. 4, 22, 8-12 (1906).

56. Rümelin, G. The rate of transformation of the radium emanation. Phil. Mag., ser. 6, 14, 550-553 (1907).

57. Godlewski, T. Actinium and its

successive products. Phil. Mag., ser. 6, 10, 35-45 (1905).

58. Godlewski, T. Some radioactive properties of uranium. Phil. Mag., ser. 6, 10, 45-60 (1905).

59. Godlewski, T. On the absorption of the β and γ rays of actinium. Phil. Mag., ser. 6, 10, 375-379 (1905).

60. Cohen, M. Rutherford's curriculum vitae, 1894-1907. Med. Physics, 22, 841-859 (1995).

61. Eve, AS. The changes in velocity, in an electric field, of the α , β and secondary rays from radioactive substances. Phil. Mag., ser. 6, 15, 720-737 (1908).

62. Eve, AS. On the amount of radium emanation in the atmosphere near the earth's surface. Phil. Mag., ser. 6, 16, 622- 632 (1908).

63. Eve, AS. The secondary rays due to the rays of radium C. Phil. Mag., ser. 6, 16, 224-234 (1908). Also (identical paper): Trans. Roy. Soc. Can., sec. III, 5-13 (1908).

64. Eve, AS. Primary and secondary gamma rays. Phil. Mag., ser. 6, 18, 275-291 (1909).

65. Eve, AS. On the amount of radium present in sea water. Phil. Mag., ser. 6, 18, 102-107 (1909).

66. Eve, AS. The effect of dust and smoke on the ionization of air. Phil. Mag., ser. 6, 19, 657-673 (1910).

67. Eve, AS. On the number of ions produced by the gamma radiation from

radium. Phil. Mag., ser. 6, 27, 394-396 (1914).

68. Barnes, HT, Shaw, AN. A phenomenon connected with the discharge of electricity from pointed conductors. Proc. Roy. Soc. A, 82, 336-350 (1909).

69. Barnes, HT. The absolute value of the mechanical equivalent of heat, in terms of the International Electrical Units. Proc. Roy. Soc. A, 82, 390-395 (1909).

70. Barnes, HT. The Dawson isothermal layer of low temperature in the Gulf of St. Lawrence. Trans. Roy. Soc. Can., ser. 3, 8, sec. III, 75-82 (1914).

71. Barnes, HT. Effect of strain on the coefficient of expansion of quartz. Trans. Roy. Soc. Can., ser. 3, 9, sec. III, 147-149 (1915).

72. King, LV. Absorption problems in radioactivity. Trans. Roy. Soc. Can., ser. 3, 5, sec. III, 97-105 (1911).

73. King, LV. On the scattering and absorption of light in gaseous media, with applications to the intensity of sky radiation. Phil. Trans. 212A, 375-433 (1912).

74. King, LV. On the gradient of the penetrating radiation from the earth. Phil. Mag., ser. 6, 26, 604-611 (1913).

75. King, LV. On the determination of Avogadro's Number and the electronic charge by the application of Rayleigh's Law to the Smithsonian observations of the absorption of solar radiation by the earth's atmosphere. Trans. Roy. Soc.

Can., ser. 3, 8, sec. III, 59-64 (1914).

76. King, LV. On the precision measurement of air velocity by means of the linear hot-wire anemometer. Phil. Mag., ser. 6, 29, 556-577 (1915).

77. King, LV. On the density of molecules in interstellar space. Trans. Roy. Soc. Can., ser. 3, 9, sec. III, 99-103 (1915).

78. King, LV. On the determination of the electrical and acoustic characteristics of telephone receivers. J. Franklin Inst., 187, 611-625 (1919).

79. Wilson, HA. On the statistical theory of heat radiation. Phil. Mag., ser. 6, 20, 121-125 (1910).

80. Wilson, HA. The electron theory of the optical properties of metals. Phil. Mag., ser. 6, 20, 835-844 (1910).

81. Wilson, HA. The velocity of the ions of alkali salt vapours in flames. Phil. Mag., ser. 6, 21, 711-718 (1911).

82. Wilson, HA. The number of electrons in the atom. Phil. Mag., ser. 6, 21, 718-722 (1911).

83. Wilson, HA. The number of electrons in atoms. Trans. Roy. Soc. Can., ser. 3, 5, sec. III, 47-51 (1911).

84. Boyle, RW. The effect of temperature and velocity of gas current on the absorption of radioactive emanations by charcoal. Trans. Roy. Soc. Can. ser. 3, 1, sec. III, 85-111 (1907).

85. Boyle, RW. Some further results on the absorption of thorium emanation by

charcoal. Trans. Roy. Soc. Can., ser. 3, 2, sec. III, 141-151 (1908).

86. Boyle, RW. The absorption of radioactive emanations by charcoal. Phil. Mag., ser. 6, 17, 374-388 (1909).

87. Boyle, RW. The volatilization of radium emanation at low temperatures. Phil. Mag., ser. 6, 20, 955-966 (1910).

88. Boyle, RW. The behaviour of radium emanation at low temperatures. Phil. Mag., ser. 6, 21, 722-732 (1911).

89. Gray, JA. The similarity in nature of X- and primary γ -rays. Proc. Roy. Soc., A, 87, 489-501 (1912).

90. Gray, JA. The scattering and absorption of the γ rays of radium. Phil. Mag. ser. 6, 26, 611-623 (1913). Also (identical paper!): Trans. Roy. Soc. Can., ser. 3, 7, sec. III, 139-149 (1913).

91. Gray, JA. The penetrating power of the γ rays excited in lead by the β rays of radium E. Trans. Roy. Soc. Can., 8, sec. III, 181-184 (1914).

92. Gray, JA. The scattering of X- and γ -rays. J. Franklin Inst., 190, 633-655 (1920).

93. Gray, JA. The softening exhibited by secondary X-rays. Trans. Roy. Soc. Can., ser.3, 16, sec. III, 129-134 (1922).

94. Gray, JA. Note on secondary X-rays. Trans. Roy. Soc. Can., ser.3, 7, sec. III, 165-166 (1923).

95. Compton, AH. A quantum theory of the scattering of X-rays by light elements. Phys. Rev., 21, 483-502 (1923).

96. Lewis, WB. Joseph Alexander Gray, 1884-1966. Biographical Memoirs of Fellows of the Royal Society, pp. 89-106 (1967).

97. Shaw, AN. Secondary cathode rays from gases. Trans. Roy. Soc. Can., ser.3, 9, sec. III, 13-16 (1915).

98. Shaw, AN and Henry, V. The analysis of simple periodic curves by a projection method, with special reference to estuary tidal problems. Trans. Roy. Soc. Can., ser.3, 13, sec. III, 139-151 (1919).

99. Shaw, AN. The mutual potential energies of circular coils and small magnets. Trans. Roy. Soc. Can., ser. 3, 13, sec. III, 153-158 (1919).

100. Shaw, AN and Reilley, HE. The effects of aging in standard Weston cells of a modified type. Trans. Roy. Soc. Can., ser. 3, 13, sec. III, 171-176 (1919).

101. Bronson, HL. The construction and calibration of very high resistances and a standard of high resistance. Trans. Roy. Soc. Can., ser. 3, 2, sec. III, 163-169 (1908).

102. Bronson, HL. On α rays from radium B. Phys. Rev. 38, 452- 453 (1909).

103. Bronson, HL and Shaw, AN On the reproducibility of the Clark and Weston Cells, and a recalculation of the mechanical equivalent of heat. Phys. Rev. 38, 453-455 (1909).

104. Wheeler, NE. The cubical expansion of vitreous quartz. Trans.

Roy. Soc. Can., ser.3, 8, sec. III, 139-156 (1914).

105. James, CB. A determination of the coefficient of expansion of mercury at low temperatures. Trans. Roy. Soc. Can., ser.3, 8, sec.III, 51-58 (1914).

106. Moran, J. A comparison of radium standard solutions. Trans. Roy. Soc. Can., ser.3, 9, sec. III, 27-32 (1915).

107. King, LV. On the design of diaphragms capable of continuous tuning. Proc. Roy. Soc. A 99, 163-171 (1921).

108. King, LV. On some new formulae for the numerical calculation of the mutual induction of coaxial circles. Proc. Roy. Soc. A, 100, 60-66 (1922).

109. King, LV. On the complex anisotropic molecule in relation to the dispersion and scattering of light. Proc. Roy. Soc. A, 104, 333-357 (1923).

110. King, LV. Electromagnetic shielding at radio frequencies. Phil. Mag., ser. 7, 15, 202-223 (1933).

111. King, LV. On the acoustic radiation field of the piezo- electric oscillator and the effect of viscosity on transmission. Can. J. Res. 11, 135-155 and 484-488 (1934).

112. King, LV. On the acoustic radiation pressure on circular discs: inertia and diffraction corrections. Proc. Roy. Soc .A, 153, 1-16 (1935).

113. King, LV. On the theory of the inertia and diffraction corrections for the Rayleigh disc. Proc. Roy. Soc. A., 153, 17-40 (1935).

114. King, LV. On the electrical and acoustic conductivities of cylindrical tubes bounded by infinite flanges. Phil. Mag., 21, 128-144 (1936).

115. King, LV. On the radiation field of a perfectly conducting base insulated antenna over a perfectly conducting plane earth, and the calculation of radiation resistance and reactance. Phil. Trans. Roy. Soc. A, 236, 381-422 (1937).

116. Shaw, AN. A note on the formation of heavy ice in a cryophorous. Trans. Roy. Soc. Can., ser. 3, 18, sec. III, 187-189 (1924).

117. Shaw, AN and Reilley, HE. The maintenance of a standard of electromotive force: notes on standard Weston cells. Can. J. Res., 3, 473-489 (1930).

118. Shaw, AN. The rapid derivation of thermodynamical relations. Trans. Roy. Soc. Can. ser. 3, 26, sec. III, 187-204 (1932).

119. Snell, AH and Shaw, AN. The comparison of gaseous densities by the method of balancing columns. Can. J. Res., 6, 309-321 (1932).

120. Shaw, AN. The derivation of thermodynamical relations for a simple system. Phil. Trans. Roy. Soc., ser. A, 234, 299-328 (1935).

121. Foster, JS. Observations on the Stark effect in hydrogen and helium. Phys. Rev., ser. 2, 23, 667-684 (1924).

122. Foster, JS. Observed Stark effect patterns in helium. Nature, 116, 135

(July 25, 1925).

123. Foster, JS. Discharge of electricity through gases, Nature, 117, 197 (Feb. 6, 1926).

124. Foster, JS and Chalk, ML. Observed relative intensities of Stark components in hydrogen. Nature, 118, 592 (Oct. 23, 1926).

125. Foster, JS. Stark patterns observed in helium. Proc. Roy. Soc. A, 114, 47-65 (1927).

126. Foster, JS. Application of quantum mechanics to the Stark effect in helium. Proc. Roy. Soc. A, 117, 137-163 (1927).

127. Foster, JS and Chalk, L. Relative intensities of Stark components in hydrogen. Proc. Roy. Soc. A, 123, 108-118 (1929).

128. Foster, JS. and Rowles, W. Patterns and Paschen-Back analogue in the Stark effect for neon. Proc. Roy. Soc. A, 123, 80- 103 (1929).

129. Foster, JS. Effect of combined electric and magnetic fields on the helium spectrum. Proc. Roy. Soc. A, 122, 599-603 (1929) and 131, 133-146 (1931).

130. MacDonald, JKL. Stark effect in a violet region of the secondary spectrum of hydrogen. Proc. Roy. Soc. A, 123, 103-107 (1929).

131. Foster, JS and Douglas, AV. Analysis of profiles of helium lines in spectra of β stars. Nature 134, 417-418 (Sept.15, 1934)

132. Foster, JS and Snell, AH. Stark effect for hydrogen isotopes. *Nature* 133, 568 (April 14, 1934).
133. Snell, H. The Stark effect in the molecular spectrum of hydrogen. *Phil. Trans. Roy. Soc.* 234, 115-144 (1935).
134. Foster, JS and Snell, H. The Stark effect in hydrogen and deuterium. *Proc. Roy. Soc. A* 162, 349-356 (1937).
135. Panter, SF and Foster, JS. Stark effect in iron and the contrast with pole effect. *Proc. Roy. Soc. A* 162, 336-348 (1937).
136. Foster, JS. The Stark effect in argon and krypton. *Phil. Trans. Roy. Soc.* 236, 473-493 (1938).
137. Foster, JS and Douglas, AV. Stark effect in β stars. *Monthly Notices, Roy. Astron. Soc.*, 99, No. 3, 150-167 (1939).
138. Foster, JS. The Stark effect and some related phenomena. *Reports on Progress in Physics*, 5, 233-241 (1939).
139. Foster, JS, Langstroth, GO and McRea, DR. Quantitative spectrographic analysis of biological material. I.- A method for the determination of lead in cerebrospinal fluid. *Proc. Roy. Soc. A*, 153, 141-152 (1935).
140. Douglas, AV. The absorption and effective range of the β -Rays from radium E. *Trans. Roy. Soc. Can.*, 16, sec. 3, 113-124 (1922).
141. Douglas, GV and Douglas, AV. A note on the interpretation of the Wegener frequency curve. *Geol. Mag.*, 60, 108-111 (Mar. 1923).
142. Douglas, AV. Note on ionization clouds in an expansion chamber. *Trans. Roy. Soc. Can.*, 18, sec. 3, 133-136 (1924).
143. Douglas, AV. The winter sky. *J. Roy. Astro. Soc. Can.*, 18, 102-105 (1924).
144. Douglas, AV. The summer sky. *J. Roy. Astro. Soc. Can.*, 18, 195-198 (1924).
145. Douglas, AV. Real and apparent radial velocities. *Roy. Astro. Soc., Monthly Notices*, 84, 491-493 (May 1924).
146. Douglas, AV. Measuring the universe. *Discovery*, 5, 196-198, (Sept. 1924).
147. Douglas, AV. Spectroscopic absolute magnitudes and parallaxes of 200 A-type stars. *J. Roy. Astro. Soc. Can.*, 20, 265-308 (1926).
148. Douglas, AV. The cyanogen band near 4200 in the spectra of three cepheid variables. *Roy. Astro. Soc., Monthly Notices*, 90, 798-805 (Oct. 1930).
149. Douglas, AV. Note on the range in spectrum variation of Alpha Ursae Minoris. *Roy. Astro. Soc., Monthly Notices*, 90, 806-808 (Oct. 1930).
150. Douglas, AV. The total 1932 solar eclipse. *J. Roy. Astro. Soc. Can.*, 26, 211-216 (1932).
151. Douglas, AV. What we know about stars. *J. Roy. Astro. Soc. Can.*, 26, 226-230 (1932).

152. Douglas, AV. Meteors. J. Roy. Astro. Soc. Can., 26, 401-405 (1932).

153. Watson, W.H. Discontinuity in electromagnetism. Trans. Roy. Soc. Can., ser. 3, 28, sec. III, 1-27 (1934).

154. Watson, WH. Theory of optical absorption in alkali metal crystals. Can.J.Res., 10, 335-346 (1934).

155. Watson, WH. Measurement of small capacities in terms of mutual inductance and resistance. Can.J.Res., 13A, 5-9 (1935).

156. Watson, WH. Note on -transformation of electromagnetic fields. Phys.Rev., 48, 776 (1935).

157. Watson, WH and Hurst, D.G. Alkali metal films transparent in the Schumann region. Can.J.Res., 14A, 153-159 (1936).

158. Watson, WH and Hurst, DG. Transparency of sodium and potassium films in the Schumann region. Nature, 138, 124 (July 18, 1936).

159. Watson, WH. On a system of functional dynamics and optics. Phil.Trans.Roy.Soc., A 236, 155-190 (1937).

160. Watson, WH. On systems of electrostatic fields. Trans.Roy. Soc.Can., sec. III, 125-148 (1938).

161. Watson, WH. On potential momentum and momentum fields in dynamics. Can.J.Res., 18, sec. A, 1-21 (1940).

162. Keys, DA. The cathode-ray

oscillograph and its application to the exact measurement of explosion pressures, potential changes in vacuum tubes and high tension magnetos. J.Franklin Inst., 196, 577-591 (1923).

163. Keys, DA. On the adiabatic and isothermal piezo-electric constants of tourmaline. Phil.Mag., ser. 6, 46, 999-1001 (1923).

164. Keys, DA and Heard, JF. The striated discharge. Nature, 125, 971-972 (June 28, 1930).

165. Langstroth, GO. Excitation and emission in the nitrogen band spectrum. Proc.Roy.Soc.A, 150, 371-381 (1935).

166. Langstroth, GO and McRae, DR. Absorption step-weakness of antimony. Can.J.Res. 15A, 154-160 (1937).

167. Langstroth, GO and McRae, DR. Excitation in sources for spectroscopic analysis. Can.J.Res., 16A, 17-27 (1938).

168. Langstroth, GO and McRae, DR. Transport of material in sources for spectroscopic analysis. Can.J.Res., 16A, 61-74 (1938).

169. Eve, AS. Ionisation potential and the size of the atom. Nature, 107, 552-553 (June 30, 1921).

170. Eve, AS. A note on missing spectra. Phys. Rev., 19, 391 (1922).

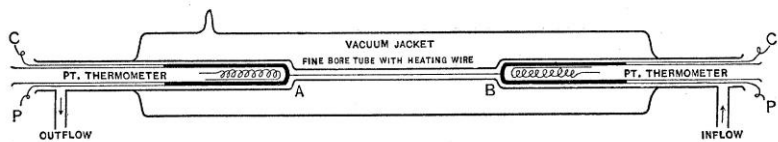

Fig. 1: Diagram of the continuous-flow electric calorimeter used by Callendar and Barnes for the measurement of the specific heat of water. A steady current of water flowing through a fine tube, AB, is heated by a steady electric current in a central conductor of platinum. The difference of temperature between the inflowing and outflowing water was measured by means of a differential pair of platinum thermometer at either end. The thermometers were read to the ten thousand part of a degree, and it is estimated that the difference was accurate to 0.001° C. (from [5])

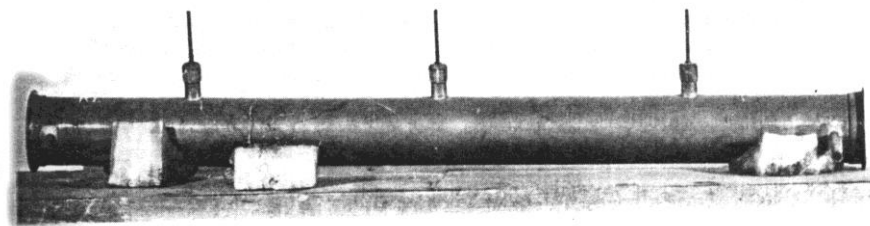
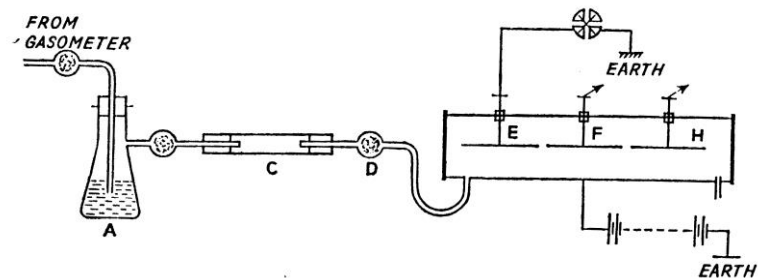

Fig. 2: Diagram of the apparatus used by Rutherford and Soddy to measure the rate of decay of thorium (and radium) emanation. Thorium in the form of fine powder is placed in vessel C. The emanation from the thorium mixed with air is carried to a long brass cylinder (shown on the right). The cylinder is connected to one pole of a battery. The ions and current in the gas generated by the decay of emanation is measured by the three electrodes E, F, and H placed along the axis of the cylinder and connected to quadrant electrometers. At the bottom is a photo of the apparatus. (from [19])

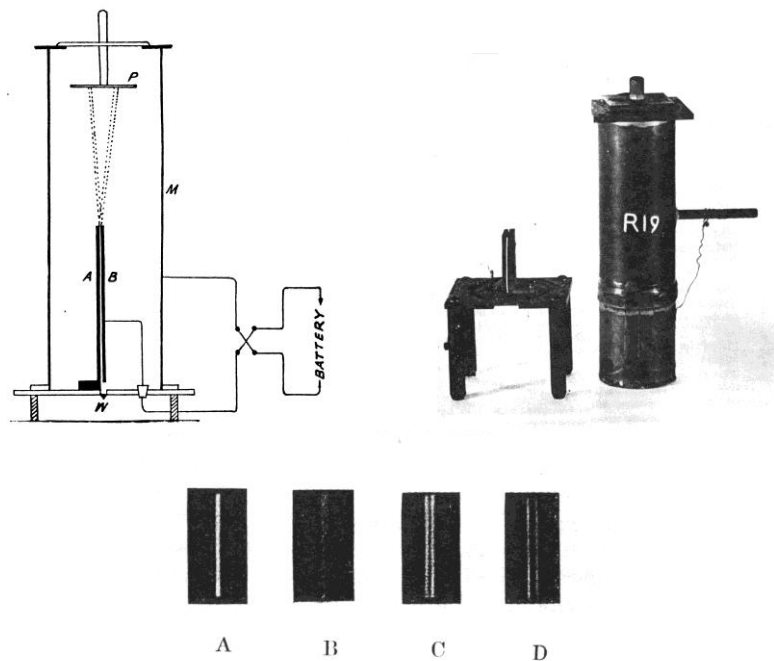

Fig. 3: Left: Diagram of one of the experimental set-up used by Rutherford in his study of the nature of α -rays. The rays from a radioactive wire W pass between two insulated parallel plates A and B spaced 0.21 mm apart and connected to a storage battery. The pencil of rays after emerging from the plates fell on a photographic plate P. Reversing the electric field at intervals reversed the direction of deflection. Right: Photos of the apparatus used by Rutherford. Bottom: A shows the natural width of the line without an electric field. Photos B, C, and D corresponds to potential differences of 255, 340, and 497 volts, respectively (from [31]). By combining these results and those of a similar experiment where he studied the deflection of α -rays induced by a magnetic field [29-30], Rutherford could determine the charge to mass ratio of the α particles and concluded that the α particles expelled from the different radio-elements have

the same mass and that this mass consistent with that of the helium atom.

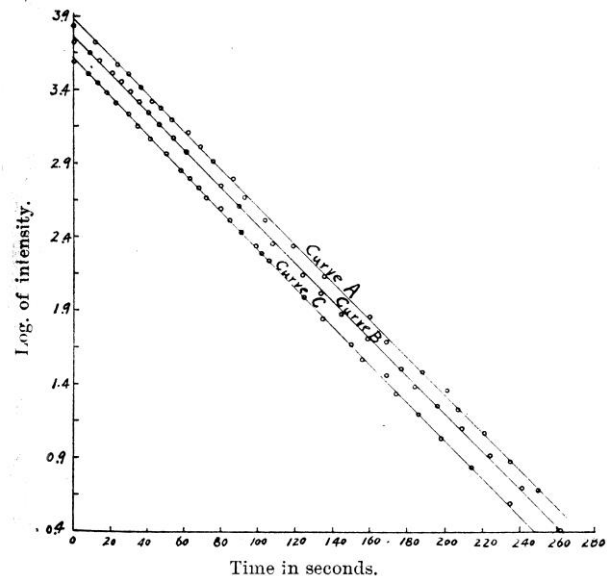

Fig. 4: Decay curves of the emanation from Thorium (Radon 220) measured by Bronson using a constant deflection method. The three curves correspond to different measurements. These had been difficult to measure because of the short decay time. Bronson obtained a value of 54 s for the half-life of the Radon 220, a value that could be compared with the present value of 55.6 s. (From [44])

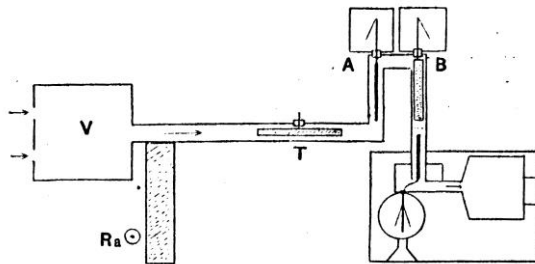

Fig. 5: Diagram of the apparatus used by Eve to study the effect of dust and smoke on the ionization of air. A flow of air passing through a thin iron cylinder V was irradiated by a radium source. The degree of ionization of the air was measured by a series of three testing vessels (A and B) attached to three electroscopes. The insulated brass cylinder T could be charged to a given potential to remove small ions in the stream of air. (from [66])

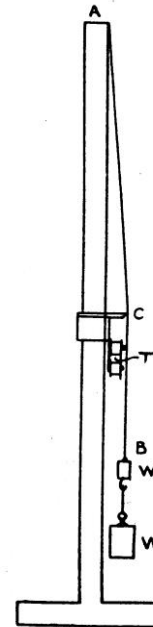

Fig. 6: Diagram of the precision sonometer used by King in his studies of the electrical and acoustical characteristics of telephone receivers. The extremity of a fine steel wire is fastened at A, the upper end of a vertical cathetometer scale. The wire is touching a sharp bevel edge C mounted on a sliding support. On this support is also mounted a telephone magnet T used to excite the wire. The lower extremity of the wire is attached to cylindrical weights W. The apparatus allowed frequency determinations over a range varying from 360 to 1600 with an accuracy represented by an error less than one part in a thousand. (from [78])

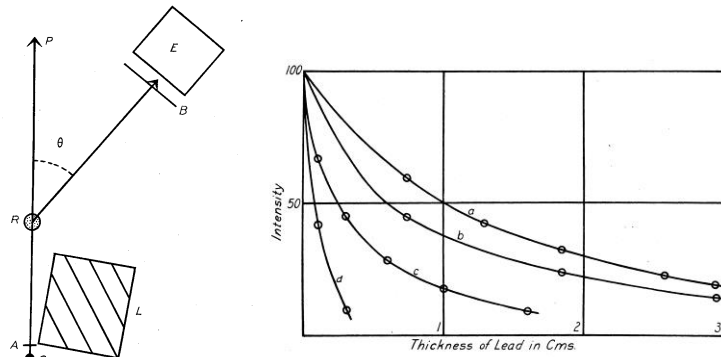

Fig. 7: Left: Disposition of the apparatus used by Gray in his study of the scattering of X- and γ - rays. A beam of rays from the source S is scattered from the radiator R. The characteristics and intensity of the scattered rays is obtained by means of the electroscope E. A thick lead brick L is used to screen the electroscope from the direct rays. A lead absorber B of various thicknesses is introduced to measure the attenuation of the scattered rays. Right. This figure shows some of the attenuation curves obtained by Gray. Curve (a) corresponds to the absorption curve of the primary rays. Curve (c) and curve (d) refers to the absorption of rays scattered through 50° and 110° respectively. Curve (b) was used to find the relative intensity of the rays scattered through 110° after different thickness of lead were placed in front of the source S (position A). From these data Gray concluded that a beam of γ - rays is changed in quality when scattered and the change depends on the angle of scattering. (from [92])

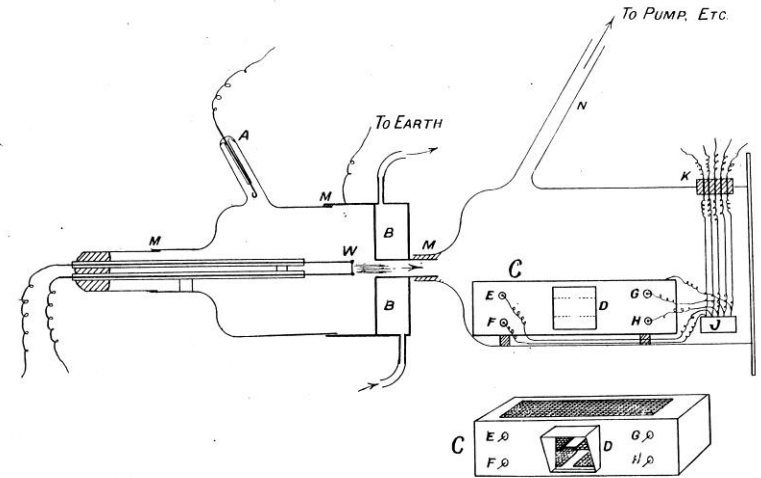

Fig. 8. Diagram of the apparatus used by Shaw in his study of secondary rays from gasses. W represents the Wennelt cathode used to produce a beam of cathode rays (electrons) that exits through a tube in a water-cooled brass collimator B. The main beam is hitting four wire mesh plates and a fine wire mesh is on top of the small brass box C. The potential on the meshes could be set by electrical connections through the ebonite plug K. D represents a window through which the luminosity in C, characteristic of secondary rays, could be observed. (from [97])

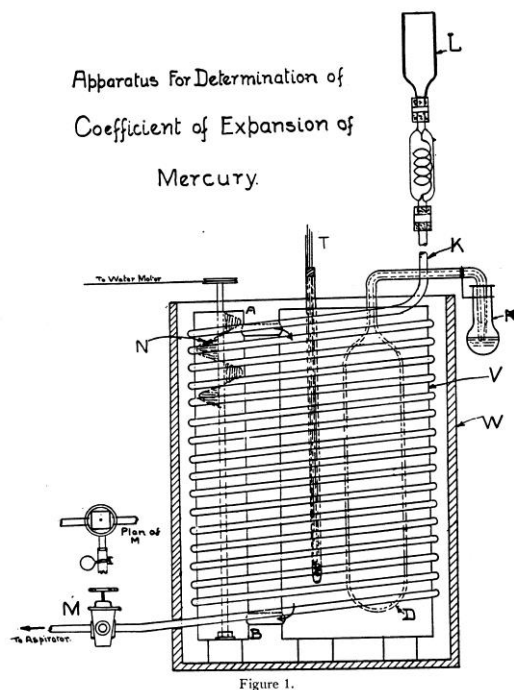

Fig. 9: Diagram of the weight dilatometer used by James for the determination of the coefficient of expansion of mercury at low temperature. The dilatometer D was made of fused quartz and was fitted with a small overflow tube at the top. The thermostat bath V was fitted with an auxiliary tube A fitted with a rotating worm N to equilibrate the temperature. This bath contained methylated spirits and was packed in an outer case W, with glass wool. Lead tubing K was wound around the bath and connected with a reservoir L containing liquid air. The lower end of the lead tube was connected to a water pump M in order to cause the liquid to flow through the lead tube. A platinum resistance thermometer T was used to

measure the temperature of the bath. The expansion of the mercury was obtained by measuring the change in weight of the mercury in the overflow vessel. (from [105])

MCGILL UNIVERSITY
MACDONALD PHYSICS LABORATORY

LECTURES for BOYS and GIRLS
CHRISTMAS 1927

Illustrated Lectures and Experimental Demonstrations

1. "LIQUID AIR AND SOLID GAS" by Professor H. E. Reilley, Thursday, Dec. 22nd, at 7.45 p.m.
2. "THE WAY OF SHIPS AT SEA" by Mr. Leslie Thomson, Monday, Dec. 26th, at 7.45 p.m.
3. "ARCS AND SPARKS" by Dr. A. S. Eve, Wednesday, Dec. 28th, at 7.45 p.m.
4. "HUNTING FOR THE UNSEEN" (A Duologue) by Dr. A. S. Eve and Dr. D. A. Keys, Friday, Dec. 30th, at 7.45 p.m.

The above lectures will be illustrated with suitable models, experiments, illustrations and lantern slides.

These lectures are intended for children about ten to fifteen years of age, but adults may come if they wish. The room will seat about two hundred only.

The price of the four tickets for all four lectures is one dollar. Tickets for separate lectures will not be sold. The tickets are transferable provided the correct ticket is presented for the corresponding lecture. Payments must be made in advance.

Kindly enclose cheque with application.
Apply in writing on or after December 1st, to

THE DIRECTOR,
Macdonald Physics Laboratory,
McGill University.

Fig. 10. Announcement of 1927 Christmas Lectures for children given by the Macdonald Physics Laboratory

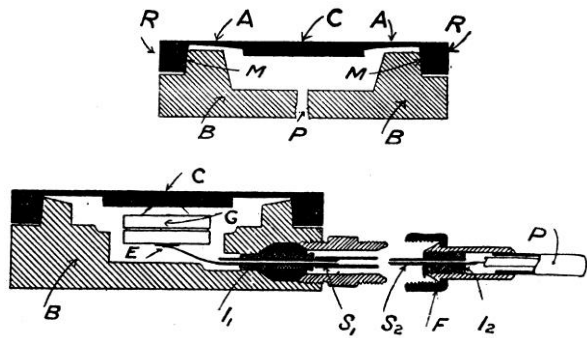

Fig. 11. Top: Diagram of the tunable diaphragms developed by King. The resonance frequency of the diaphragms was changed by the application of gaseous pressure (or suction) over the interior of the diaphragm. This had for effect to modify the tension in the thin annulus A surrounding the solid central portion C of the diaphragm. Bottom: Diagram of the tunable diaphragm used as a submarine microphone receiver. G is a carbon microphone connected to the outside through watertight insulating bushings (from [107])

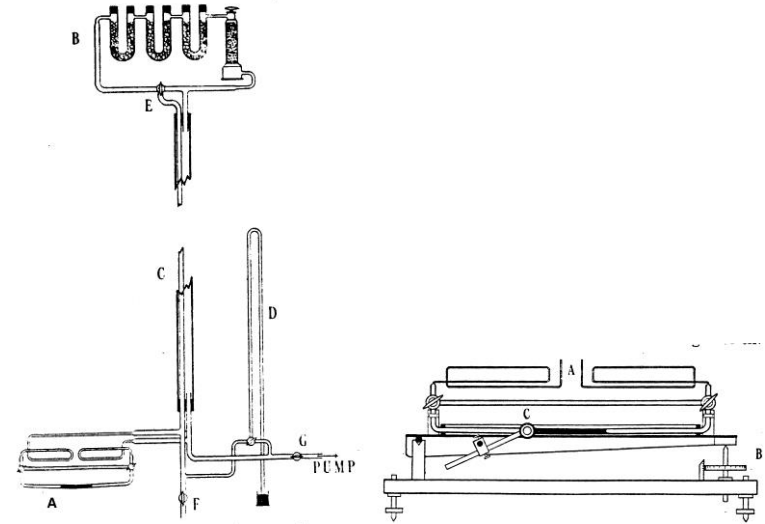

Fig. 12: Diagram of the apparatus used by Snell and Shaw for comparing gaseous densities. Left: Diagram of the balancing columns apparatus arranged for use as an absolute hygrometer. The two columns shown in C are one inside the other. The outer column contains the dry air and the inner column the air whose humidity is to be measured. The three-way cock E at the top may be connected directly for measurements or to have air pass through the drying system. The change of density is measured using a Toepler micromanometer. Right: Details of the Toepler micromanometer as modified for used with the balancing columns. Fines tubes lead from A to the bases of the columns. C is a microscope used for observing shift in the meniscus of the manometer liquid (shown in black). (from [119])

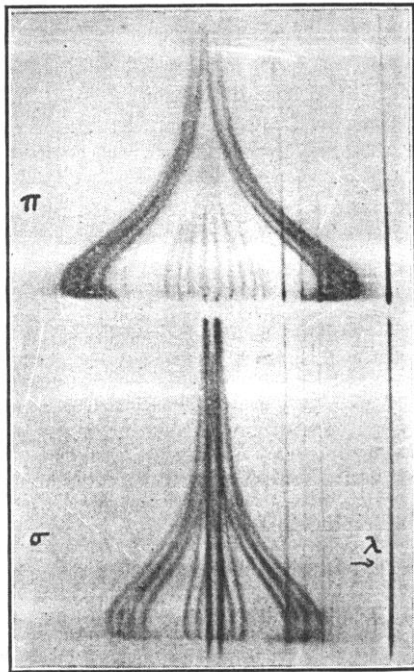

Fig. 13: Observation by Foster of the Stark Effect in the hydrogen isotopes. The figure shows the spectral lines H_γ of a mixture of hydrogen and deuterium in field up to 52 kv/cm. (from [132])

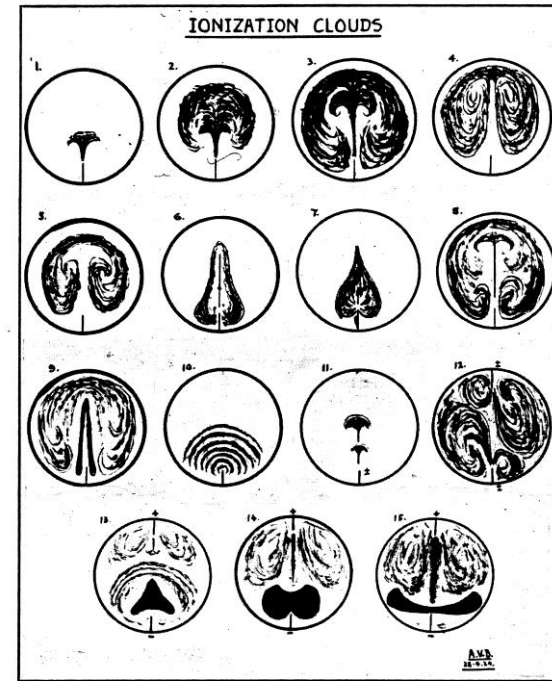

Fig. 14: Sketches of the ionization clouds produced by point discharge in an expansion chamber observed by Douglas. The discharge was produced either by means of Leyden jars or a Wimshurst Machine. The various sketches correspond to different conditions used in reaching the discharge potential. (from [142])

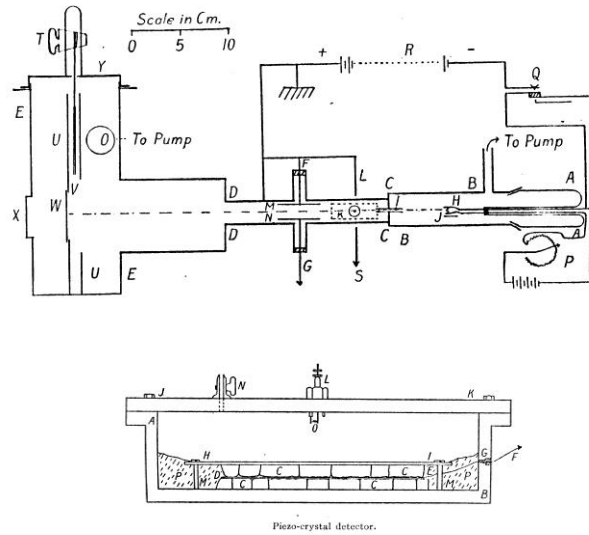

Fig. 15: Top: Diagram of the cathode-ray oscillograph used by Eve in the study of the pressure produced by explosions, the potential changes in vacuum tubes, and in high tension magnetos. The beam of cathode-ray (i.e. electrons) is generated by a heated fine tungsten wire J inserted in a ground glass tube BB. The glass tube is connected to a brass tube CC that contains two sets of deflecting plates K and MN mutually at right angles. W is a willimite (zinc silicate) fluorescent screen that can be view through the glass window X. A photographic plate V can be lowered in front of the beam for recording of the beam trace. Center: Piezo-crystal detector developed by Eve to measure the changes of pressure under water or gaseous explosion. The brass box in which is produced the explosion contains two layers of tourmaline CC with a lead plate ED between them connected to an insulated wire. A thin sheet of steel HI clamps these crystal down tightly. At the surface of the crystal appears a voltage that is proportional to the pressure on the crystal. Bottom: Reproduction of some of the photos obtained by Eve using this oscillograph. The left figure corresponds to the explosion of guncotton under water while the figure at the right is from the explosion of TNT. (from [162])

